

Part No. 29150510RC  
VAUXHALL

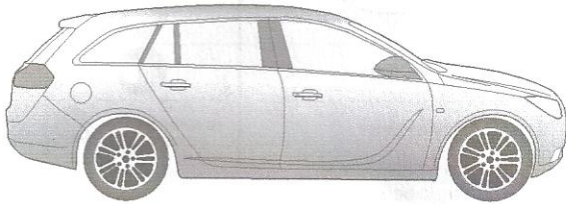

Insignia Sports Tourer 03/09 →

## Electric wiring kit for towbars / 13-pin / 12 Volt / ISO 11446 Fitting instructions

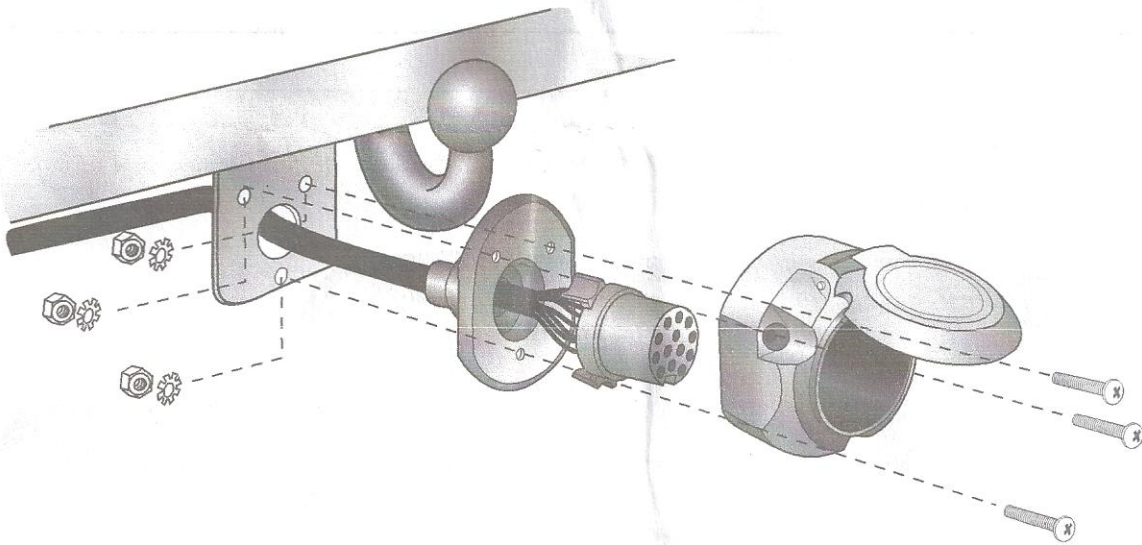

**IMPORTANT!**



Installation of the towing electrics kit must be undertaken by a specialist workshop or an appropriately qualified person. Before starting work, you must read the installation instructions through completely. After installing the towing electrics kit, the installation instructions should be kept with the vehicle service documentation.

All claims under the guarantee will lapse in case of improper use or modification of the towing electrics kit or any of its component parts. When driving without a trailer or load carrier, any adapter installed must be removed from the electrical socket. We reserve the right to alter the design, content or colour. We accept no liability for any errors in these instructions. All details and illustrations are non-binding.

In case of missing a rear fog lamp on the trailer, it should be retrofitted.

We accept no responsibility and give no guarantee for technical and electrical modifications made after the initial operation of the towing electrics kit by the vehicle manufacturer and which may lead, for example to malfunction of the trailer socket or its peripheries.

The trailer module is not diagnostics-capable. If the manufacturer's diagnostics processes or software-supported test mechanisms generate error reports directly or indirectly linked with trailer operation, the trailer module must be disconnected from the leads to the trailer socket and a new diagnostic process initiated.









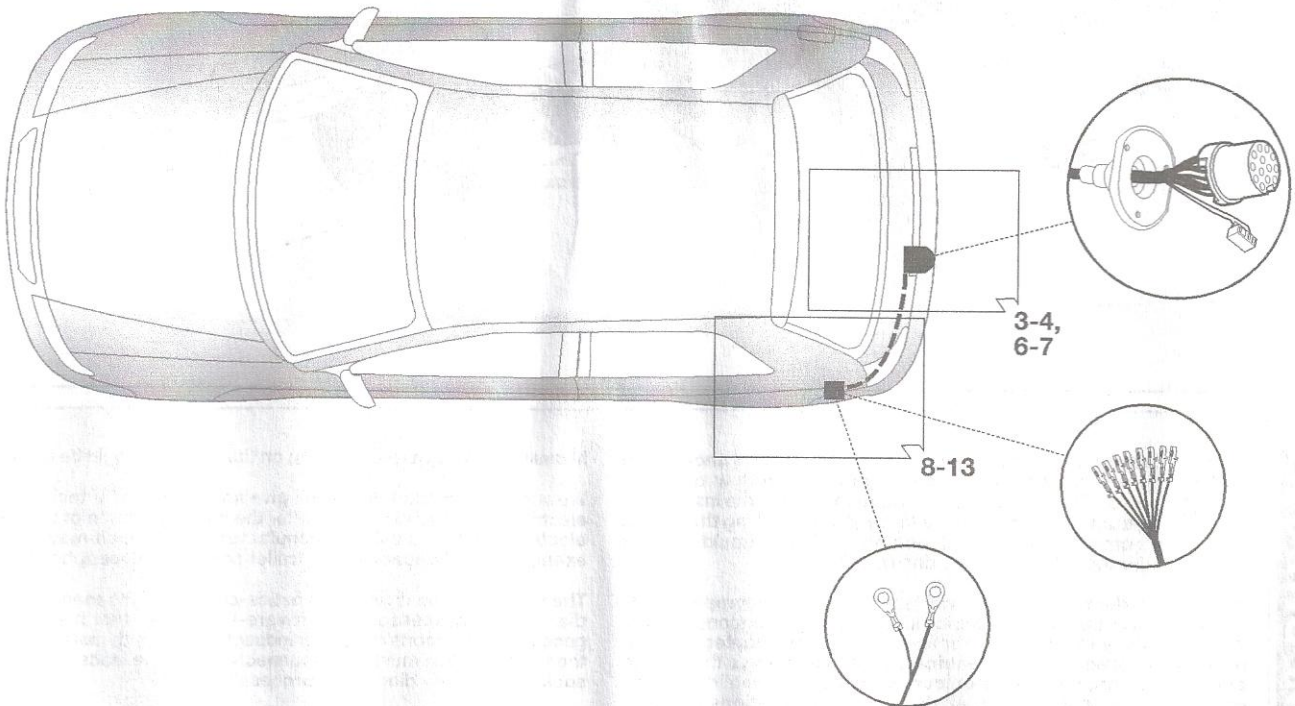





















10x

5x

90270328



## SYMBOL EXPLANATION

	left (58-L) respectively right (58-R) tail light		cigarette lighter / accessory socket
	stop light (54) / high mounted, third stop light (54)		loudspeaker / buzzer
	turn signal indicator left		Park Distance Control
	turn signal indicator right		switch / source of function
	rear fog light(s)		Connect together
	reversing light(s)		Disconnect
	Permanent power supply / 13pin socket, chamber 9		Look at / See further information
	charging wire for trailer fridge / 13pin socket, chamber 10		Look carefully at selected area
	trailer / trailer recognition		Present / Occupied / OK
	Permanent current power supply		Not present / Not occupied / Not OK
	Ground or Earth (31)		left
	ground connection battery terminal lug		right
	positive connection battery terminal lug		acoustic indication
	fuse / fuse capacity 20 Ampere		attention / important advice

90500780

## Tools

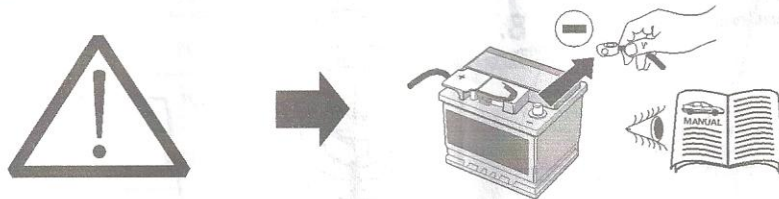
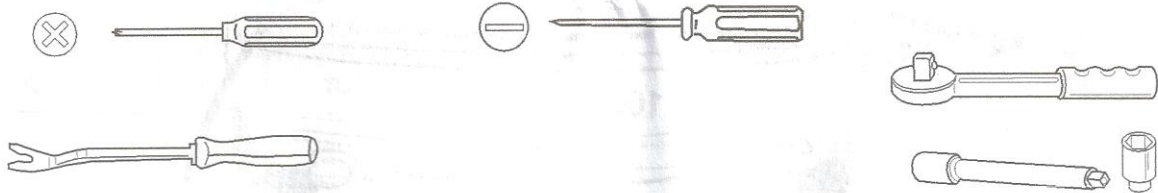

### IMPORTANT!

In order to avoid mal-functions and damage to the vehicle's electrical system the earth terminal **must** be disconnected from the vehicle's battery **before starting work!**

Both the trailer module and the vehicle's control unit for the electrical system can be damaged during work on the data bus connections if the battery is not disconnected!

Please pay attention to the manufacturer's instructions when disconnecting and reconnecting the vehicle's battery!

1

a

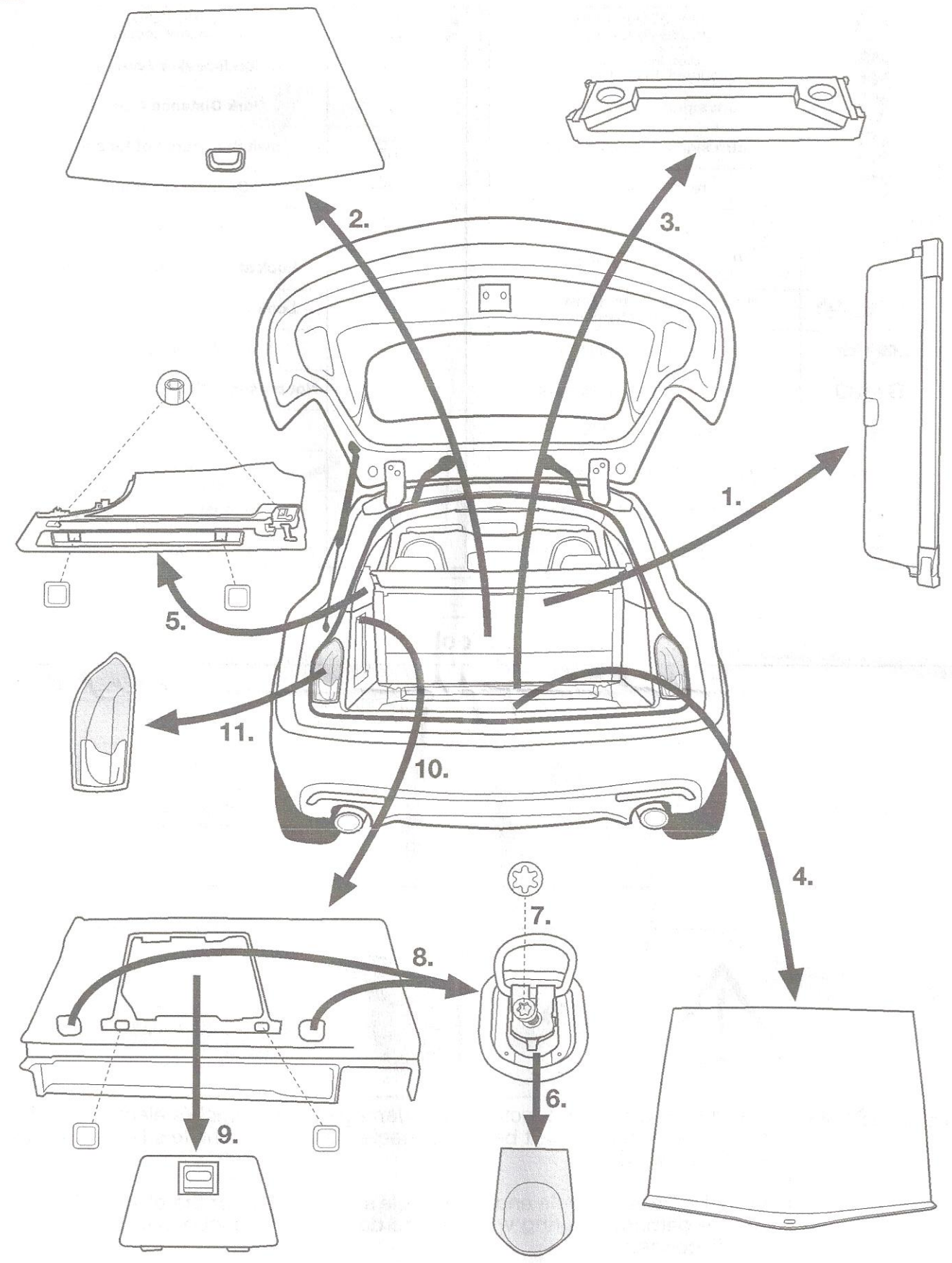

2

**OPTION 1**

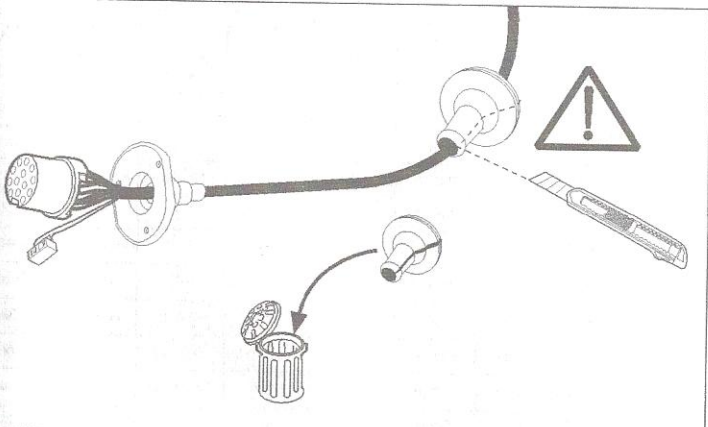
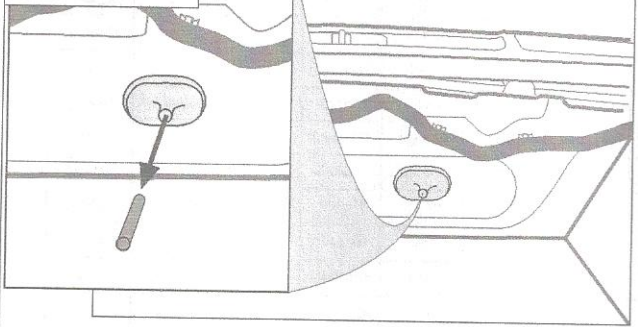

3

**OPTION 2**

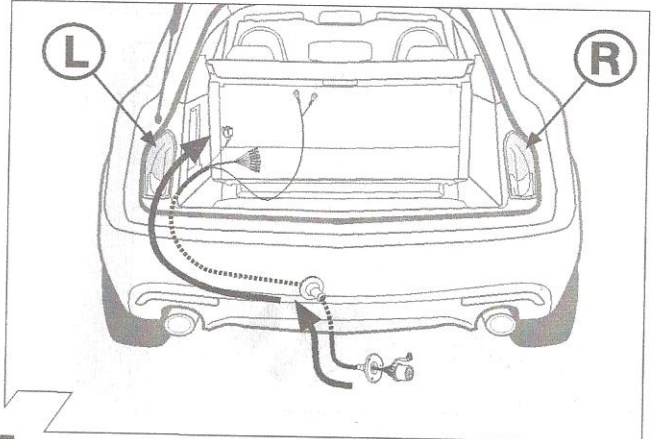
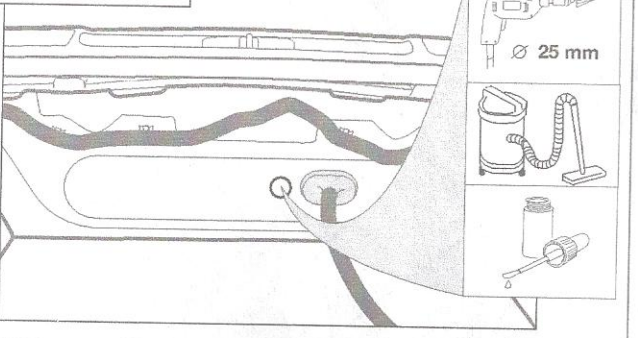

4

5

ISO 11446	Belegung der Steckdose / Maximale Ausgangsleistung Socket configuration / Maximum power output Correspondance des contacts de la prise / Puissance de sortie maximale Abbinamento della presa / Uscita di alimentazione massima Indeling van de stekkerdoos / maximaal uitgangsvermogen		
	1/L	YL	21W
	2	BL	42W
	3/31	WT	
	4/R	GN	21W
	5/58-R	BR	52W
	6/54	RD	63W
	7/58-L	BK	52W
	8	RD/BL	42W
	9	OR	240W
	10	GY	180W
	11	WT/BK	
	12		
	13	WT/RD	

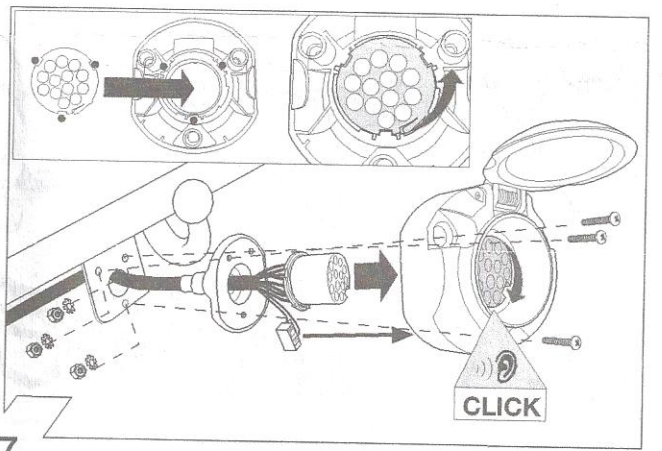

7

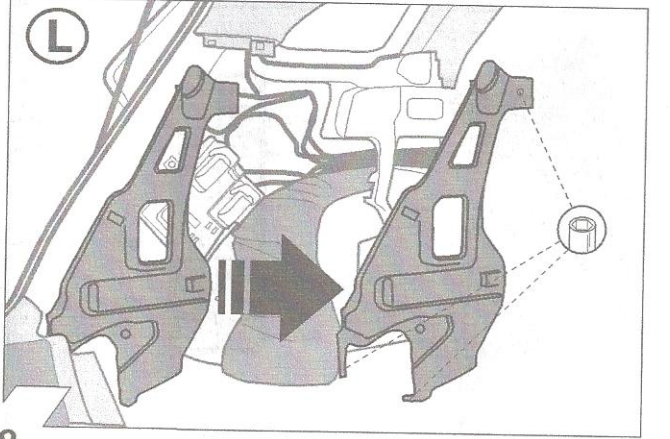

8

90020157

6

	GB	D	E	F	I	P	NL	DK	N	S	FIN	CZ	H	PL
BK	Black	Schwarz	Negro	Noir	Nero	Preto	Zwart	Sort	Svart	Svart	Musta	Černá	Fekete	Czarny
RD	Red	Rot	Rojo	Rouge	Rosso	Vermelho	Rood	Red	Red	Röd	Punainen	Červená	Piros	Czerwony
GN	Green	Grün	Verde	Vert	Verde	Verde	Groen	Grøn	Grønt	Grön	Vihreä	Zelená	Zöld	Zielony
OR	Orange	Orange	Naranja	Orange	Arancione	Laranja	Oranje	Orange	Orange	Orange	Oranssi	Oranzová	Narancs	Pomarańczowy
VT	Violet	Violett	Violeta	Violet	Viola	Violeta	Violet	Violet	Fiolett	Violett	Violetti	Fialová	Ibolya	Fioletowy
PK	Pink	Pink	Pink	Rose	Rosa	Cor-de-Rosa	Paars	Pink	Pink	Rosa	Pinkki	Růžová	Rózsaszín	Różowy
BL	Blue	Blau	Azul	Bleu	Blu	Azul	Blauw	Blå	Blått	Blå	Sininen	Modrá	Kék	Niebieski
YL	Yellow	Gelb	Amarillo	Jaune	Giallo	Amarelo	Geel	Gul	Gult	Gul	Keltainen	Zlutá	Sárga	Żółty
WT	White	Weiss	Blanco	Blanc	Bianco	Branco	Wit	Hvid	Hvitt	Vit	Valkoinen	Bílá	Fehér	Biały
BR	Brown	Braun	Marrón	Brun	Marrone	Marrom	Bruin	Brun	Brunt	Brun	Ruskea	Hnědá	Barna	Brazowy
GY	Grey	Grau	Gris	Gris	Grigio	Cinzeno	Grijs	Grå	Grått	Grå	Harmaa	Sedá	Szürke	Szary

90500580

9

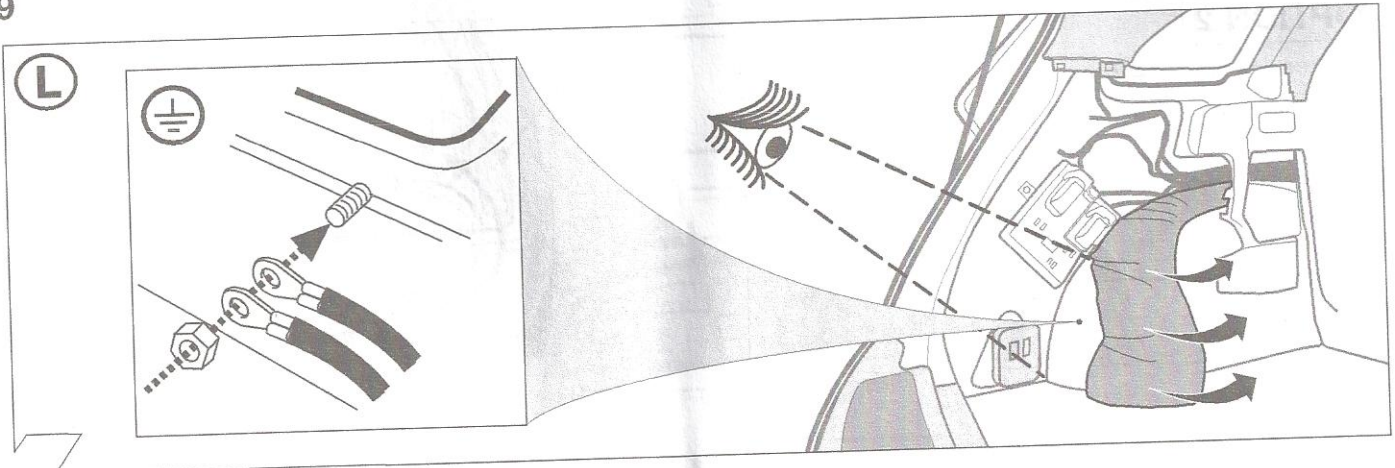

10

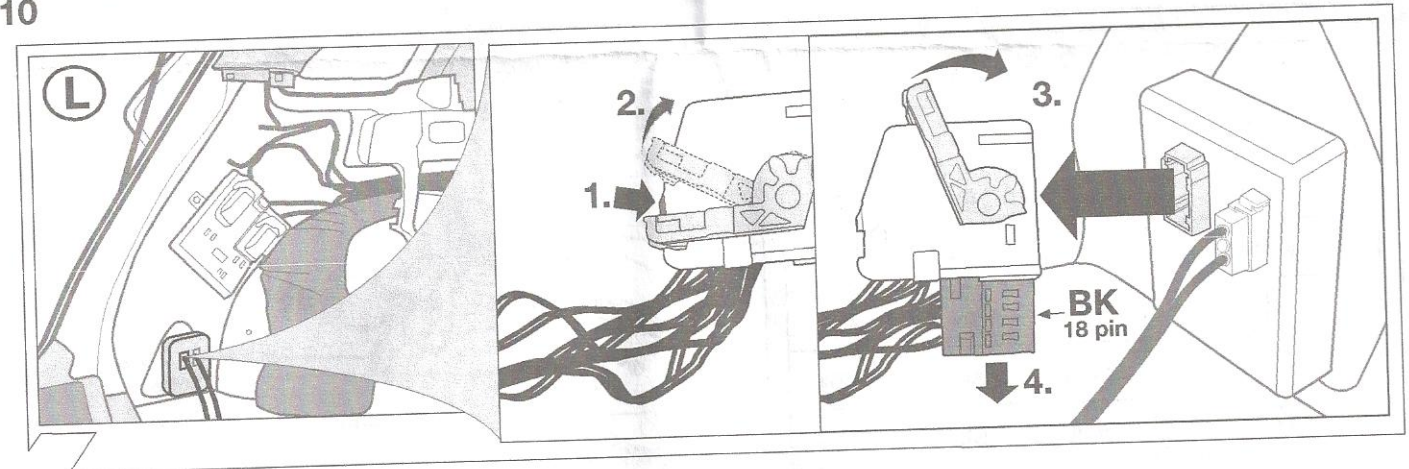

11

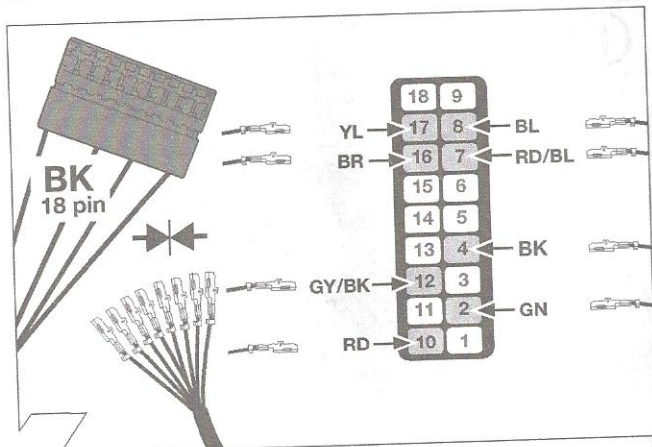

12

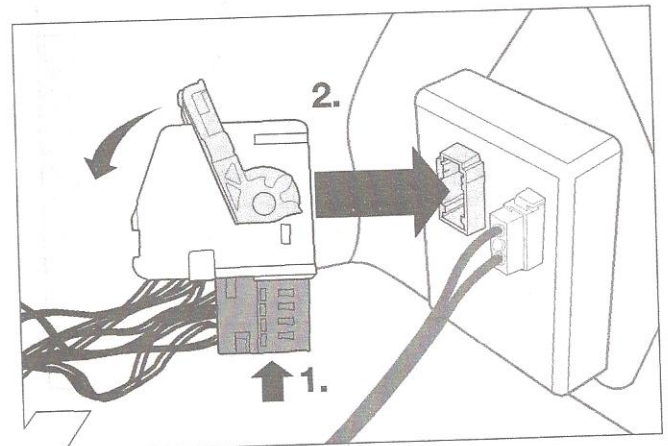

13

**OPTIONAL for voltage control relay**

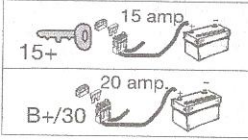
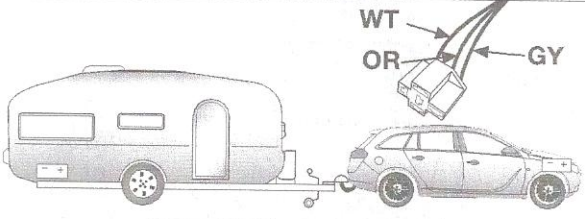

**Part-no. 22400512RC**

90500763

14

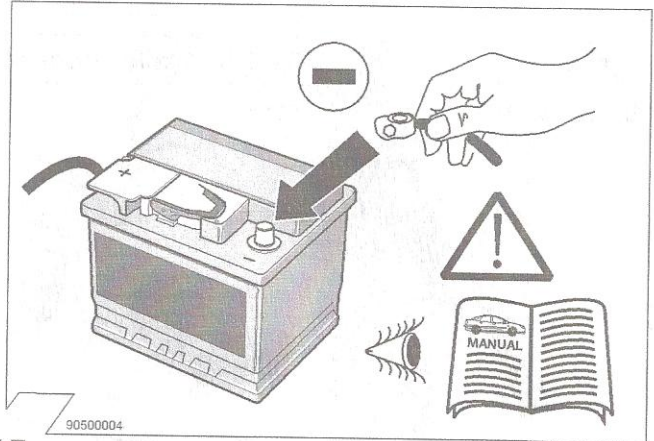

90500004

15

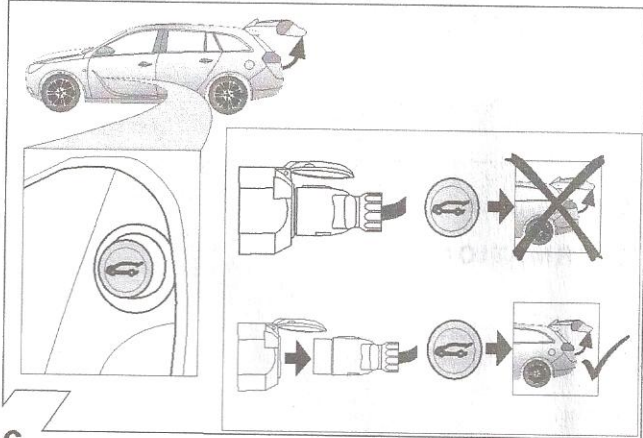

16

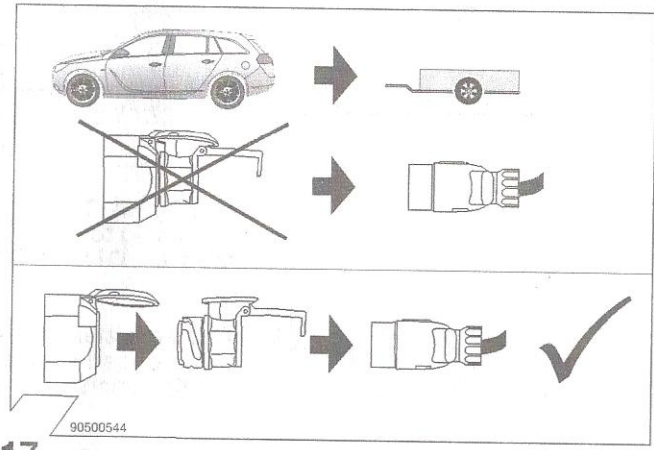

90500544

17

**Optional: Adapter socket 62400003**

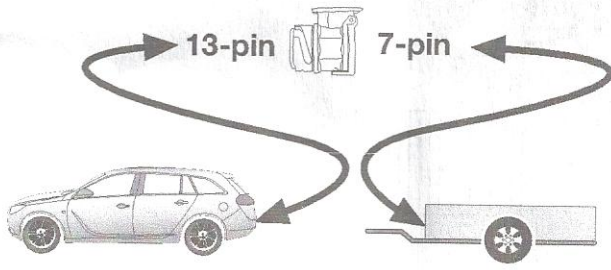

90500332

18



**Programming page 8**



### Set up trailer operation

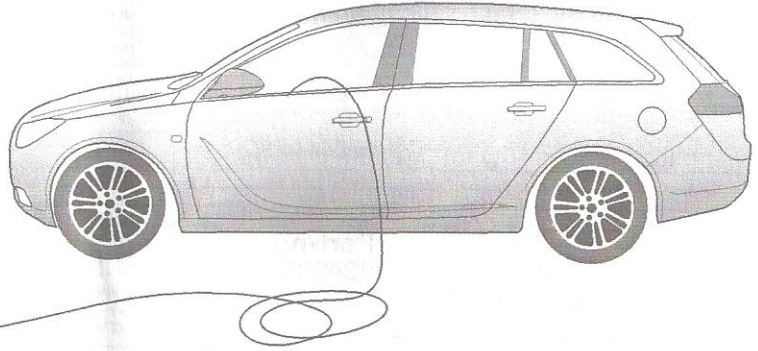
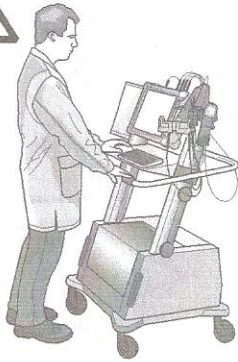

**GB**

Configure **TIM** (Trailer Interface Module) according to **OPEL DIAGNOSIS INFORMATION**.

Other assistance systems (e.g. PDC) may have to be coded separately to the "Trailer mode" configuration.

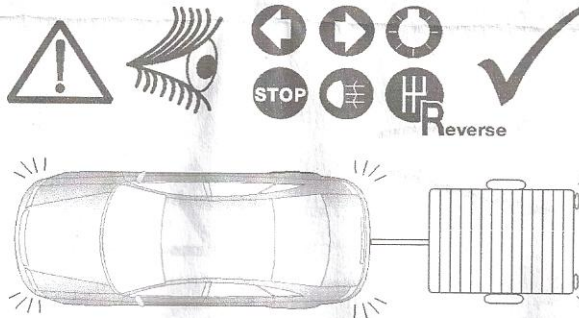



# Coding helpsheet for – Insignia Sport Tourer

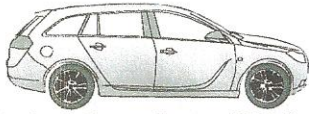

Insignia Sports Tourer 03/09 →

## STEP 1: Trailer Module Programming

After installation of the electrical kit, the trailer light functionality HAS to be programmed into the module. You will need to follow the ECU Programming sequence as shown here.

- Install MDI diagnostic equipment to car
- Open up 'BEFORE YOU START' page on SPS tab under - TIS Service & Parts Operations
- Click 'Start SPS' button
- Under 'SELECT DIAGNOSTIC TOOL' Select & highlight - J2534 MDI
- Under 'SELECT PROGRAMMING PROCESS' Select & highlight - Reprogram ECU - click NEXT
- Check J2534 Pass Thru details and click NEXT
- Select car details - Vauxhall - year - passenger car - INSIGNIA. Click NEXT
- Check VIN is displayed. Click NEXT
- Check Salesmake again as - Vauxhall and click NEXT
- Under 'SUPPORTED CONTROLLERS' & in section 'SELECT CONTROLLER, Scroll down and select/highlight TIM Trailer Interface Control Module - Programming. In the section below named SELECT PROGRAMMING TYPE, highlight 'Normal' and click NEXT.
- Under 'SUMMARY', you should now have details of your selection and will be connected to the server. When connected, NEXT button will be solid. Click NEXT.
- This will now connect to the server and download the data to the tool. Click NEXT
  
- You will now have the 'SPS - Special Function section.
- Under 'Control Module - Configuration and Setup Functions(s), select ' ECU Programming' and click NEXT.
- The Trailer ECU will now be programmed. When complete, click FINISH.
- The Control Module - Programming Functions(s) screen will now have a green 'tick' and text ECU Programming shown under Special Function Session Log. Click FINISH.
- Turn Off ignition for 30 seconds to reset the controller. Click CANCEL
- Test the trailer functions using a filament bulb tester. DO NOT use LED's or

# Coding helpsheet for – Insignia Sport Tourer

## STEP 2: Configuration & Setup

After testing the trailer functions, it is found that the flasher lamp functions cause a double flash rate to occur, you will need to follow the ECU setup/Configuration sequence as shown here.

- Install MDI diagnostic equipment to car
- Open up 'BEFORE YOU START' page on SPS tab under - TIS Service & Parts Operations
- Click 'Start SPS' button
- Under 'SELECT DIAGNOSTIC TOOL' Select & highlight - J2534 MDI
- Under 'SELECT PROGRAMMING PROCESS' Select & highlight - Reprogram ECU – click NEXT
- Check J2534 Pass Thru details and click NEXT
- Select car details - Vauxhall – year – passenger car – INSIGNIA. Click NEXT
- Check VIN is displayed. Click NEXT
- Check Salesmake again as – Vauxhall and click NEXT
- Under 'SUPPORTED CONTROLLERS' & in section 'SELECT CONTROLLER, Scroll down and select/highlight TIM Trailer Interface Control Module – Configuration & Setup. In the section below named SELECT PROGRAMMING TYPE , highlight 'Normal' and click NEXT.
- Under 'SUMMARY', you should now have details of your selection. Click NEXT.

This will now connect to the server and download the data to the tool. Click NEXT

- You will now have the 'SPS – Special Function section.
- Under 'Control Module – Configuration and Setup Functions(s), select ' ECU Configuration and click NEXT.
- The ECU will now be configured and setup into the car. When complete, click FINISH.
- The Control Module – Configuration and Setup Functions(s) screen will now have a green 'tick' and text ECU Configuration / Reconfiguration shown under Special Function Session Log. Click FINISH.
- Turn Off ignition for 30 seconds to reset the controller. Click CANCEL